



WOODWORKING
MACHINERY
SOLUTIONS



AMUZMA[®]



ABOUT US

AMUZMA is a woodworking machinery manufacturing company dedicated to delivering a wide range of high-quality machines for the modern woodworking industry. Our product line includes various types of machinery designed to meet the needs of furniture manufacturers, workshops, and industrial production units. With a strong focus on quality, durability, and performance, AMUZMA ensures that every machine is built to provide reliable operation and long-term value. We combine practical engineering with efficient design to enhance productivity, precision, and ease of use. At AMUZMA, we are committed to supporting our clients with dependable machinery solutions, consistent service, and continuous improvement to meet evolving market demands.



CONFIGURATION

	Band saw PAGE 01
	Edge Banding PAGE 02 - 04
	CNC Router PAGE 05
	Panel Saws PAGE 06 - 12
	Spindle Moulder PAGE 13
	Thickneser & Planer PAGE 14 - 19
	Dust Collectors PAGE 20 - 23

ITEMS	PAGE NO.
Band Saw 65BS	01
Edge Banding Collection	02
- Edge Banding E5	03
- Edge Banding P6	04
CNC Routers	05
Panel Saws Collection	06
- Firma 40L	07
- Forte 40PA	08
- Elite 35TS	09
- Firma 35PS	10
- Elite 35EU	11
- Elite 35PS	12
Spindle Moulder Elite 30SM	13
Planner and Thicknessers Collection	14
- Planner and Thicknesser Elite 41CM	15
- Planner and Thicknesser Elite 41CS	16
- Planner Elite 41PF	17
- Thicknesser Elite 41TH	18
- Thicknesser Firma 63TH	19
Dust Collector Collection	20
- Amuzma ABS5000	21
- Amuzma DC2200	22
- Amuzma RDC3800	23

BAND SAW
Elite 65BS



AMUZMA[®]

Precision and Power in Every Cut.

The 16" Elite 65BS Bandsaw is built for industrial strength, featuring a heavy-duty welded frame, 35mm blade support, and up to 20,000 PSI tension. Achieve fast, clean, high-precision cuts—perfect for resawing and high-volume production.

SPECIFICATIONS

Blade Specifications		Motor Power Output		4kW SI
Blade Length	4470 mm	Brake		
Blade Width	10-35 mm	<input checked="" type="checkbox"/> Foot Brake <input type="checkbox"/> Magnet Motor Brake		
Blade Speed	1500 m/min	Extractor Port Diameter		2×100 mm
Max Depth of Cut		Net/Gross Weight		323/359 Kgs
<input checked="" type="checkbox"/> With bearing guide.	370 mm	Wood box dimensions		
<input type="checkbox"/> With European style roller guide	370 mm	HxLxW		1119 x 777 x 2070mm
Throat Width	580 mm	Dimensions		
Table Size	700×608 mm	HxLxW		2017 x 1201 x 889mm
Table Tilt	0-20°			
Band wheel Diameter	610 mm			

Standard Equipment Optional Equipment

ACCESSORIES



Lower Blade Guides



Upper Blade Guide & Guard



Miter Gauge

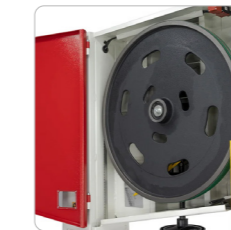

Band Saw Wheel (Flywheel)

DIMENSIONS

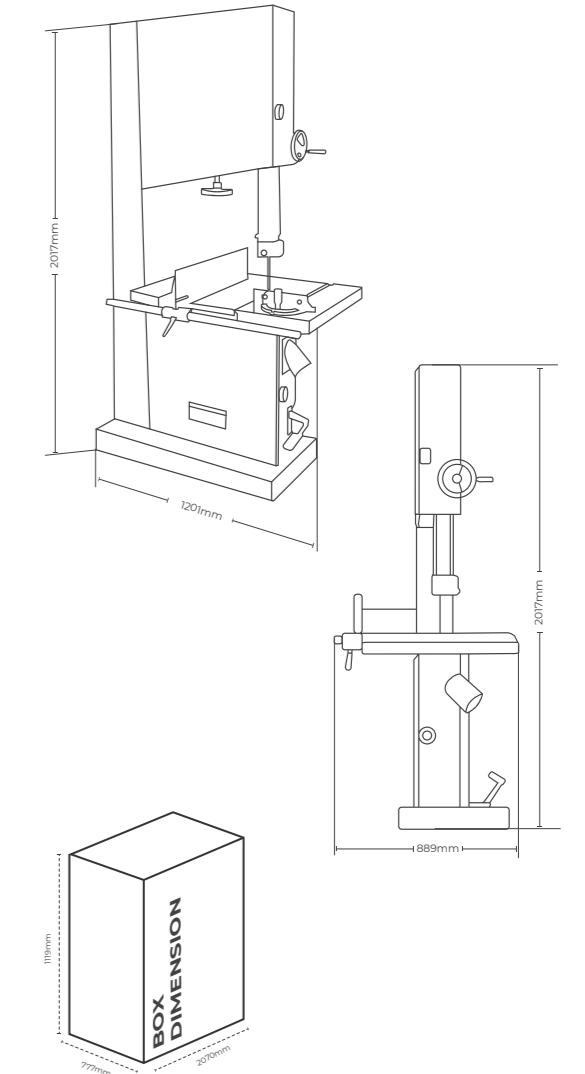

EDGE BANDING

AMUZMA®



Premium Edge Banding Machinery Series

Our industrial-grade Edge Banding Woodworking Machinery lineup—comprising the high-performance ELITE Series (E5, P6, C7) and the robust FORTE Series (E5, P6, P7)—is engineered to deliver flawless, seamless edge finishing for high-volume panel processing. Designed for precision and durability, these modules integrate advanced functionalities, including automated pre-milling, precise gluing, end-trimming, and fine buffing, to effortlessly handle PVC, ABS, veneer, and solid wood strips. Whether you choose the agile precision of the ELITE modules or the heavy-duty throughput of the FORTE configurations, our edge banders ensure perfect adhesion, crisp corners, and a market-ready finish on every laminate or composite panel.

CONFIGURATION

TECHNICAL SPECIFICATIONS	ELITE E5	ELITE P6
Thickness of edge-banding belt	0.4-3 mm	0.4-3 mm
Height of Edge-banding tape	12-45 mm	12-45 mm
Workpiece thickness	10-45 mm	10-45 mm
Feeding speed	11m/min	11m/min
Air pressure	0.6-0.8 Mpa	0.6-0.8 Mpa
Gross power	6.5 kVv	6.5 kVv
Machine outline size	mm	mm
Weight	800 Kg	800 Kg
Machine (Height)	1300mm	1300mm
Machine (length)	3150mm	3850mm
Machine (Width)	70mm	70mm
package (Height)	1280mm	1280mm
Package (length)	2900mm	3400mm
Package (Width)	650mm	650mm

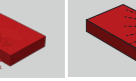
Unit Standard											
#####	Pre-milling	Lower EVA glue pot gluing system	End Cutting	Rough Trimming	Fine Trimming	Corner Rounding	Scraping	Flexible Flat Scraping	Spray	Buffing	Slotting
ELITE E5		■	■		■		■	■	■	■	
ELITE P6	■	■	■		■		■	■	■	■	



The Amuzma E5 is a reliable and efficient edge banding machine designed for precision, speed, and ease of use. Perfect for small to medium-sized workshops, this machine delivers consistent, high-quality edge finishes on MDF, plywood, particleboard, and similar panel materials. Built with a compact footprint and equipped with essential features for clean, tight bonding, the E5 offers excellent value for workshops looking to improve productivity and finish quality without investing in a large, industrial unit.

SPECIFICATIONS

Thickness of edge-banding belt	0.4-3 mm
Height of Edge-banding tape	12-45 mm
Workpiece thickness	10-45 mm
Feeding speed	11m/min
Air pressure	0.6-0.8 Mpa
Gross power	6.5 kW
Machine outline size	mm
Weight	800 Kg
Packing size	
L	2900mm
W	650mm
H	1280mm
Overall Dimensions	3150 x 700 x 1300 mm

ACCESSORIES



Trimming Units

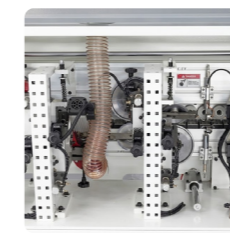

Gluing and Pressure Unit



Position Adjustment Handle



PLC Touchscreen Control Panel

DIMENSIONS

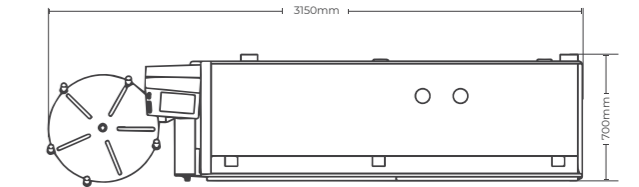
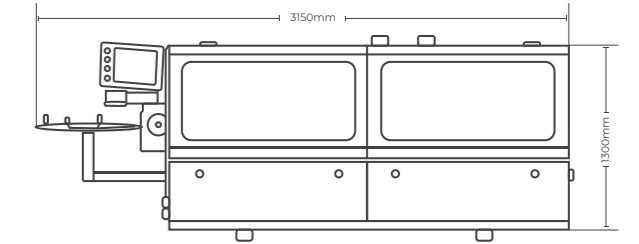

PACKAGE



The Amuzma P6 is a reliable and efficient edge banding machine designed for precision, speed, and ease of use. Perfect for small to medium-sized workshops, this machine delivers consistent, high-quality edge finishes on MDF, plywood, particleboard, and similar panel materials. Built with a compact footprint and equipped with essential features for clean, tight bonding, the P6 offers excellent value for workshops looking to improve productivity and finish quality without investing in a large, industrial unit.

SPECIFICATIONS

Thickness of edge-banding belt	0.4-3 mm
Height of Edge-banding tape	12-45 mm
Workpiece thickness	10-45 mm
Feeding speed	11m/min
Air pressure	0.6-0.8 Mpa
Gross power	6.5 kW
Machine outline size	mm
Weight	1000 Kg
Packing size	
L	3400mm
W	650mm
H	1280mm
Overall Dimensions	3850 x 700 x 1300 mm

ACCESSORIES



Trimming Units

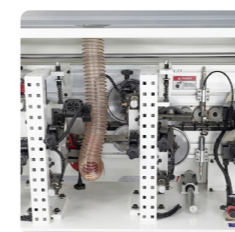

Gluing and Pressure Unit

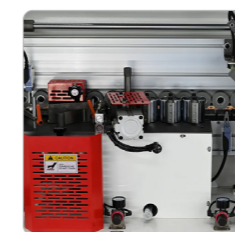

Position Adjustment Handle



PLC Touchscreen Control Panel

DIMENSIONS

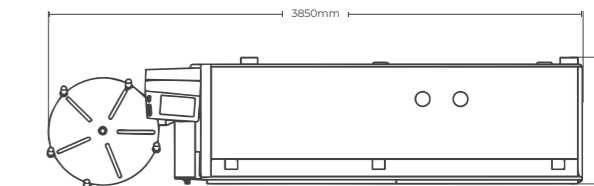
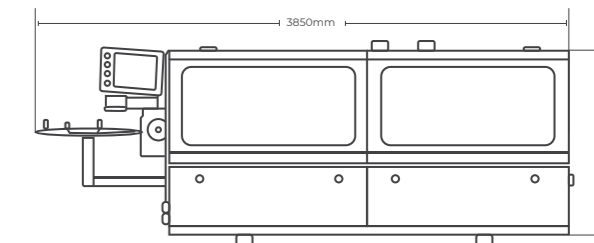

PACKAGE

CNC Router

Forte 13CR / 15CR

AMUZMA[®]



High-Precision CNC Router

A powerful and precise CNC router designed for professional woodworking and fabrication. The 13CR/15CR Amuzma offers a sturdy frame, smooth motion control, and reliable performance for cutting, engraving, and shaping materials like wood, acrylic, plastic, and soft metals perfect for makers, designers, and small workshops.

CONFIGURATION

TECHNICAL FEATURES	FORTE 13CR	FORTE 15CR
Working Table	Aluminum profile table+T slots	Aluminum profile table+T slots
Working Area	1300*2500*200	1500*3000*200
Control System	Richauto DSP All control system	Richauto DSP All control system
Spindle Motor	HQD 6.0kw air-cooling spindle	HQD 6.0kw air-cooling spindle
Inverter	Delta 7.5kw inverter	Delta 7.5kw inverter
Drive System	Delta 750W servo motor and driver	Delta 750W servo motor and driver
Speed Reducer	China oubang reducer	China oubang reducer
Guide Rails	Taiwan HIWIN 25/25/25mm square rails	Taiwan HIWIN 25/25/25mm square rails
Transmission	PCRCH 1.5M Helical rack	PCRCH 1.5M Helical rack
Z-Axis Transmission	Taiwan 2505 TBI ball screw on Z axis	Taiwan 2505 TBI ball screw on Z axis
Lubrication System	Auto lubrication	Auto lubrication
Control Cabinet	Independent control cabinet D06	Independent control cabinet D06
Safety Sensors	Autonics Limit switch	Autonics Limit switch
Electrical Components	Schneider electrical components	Schneider electrical components

ACCESSORIES



Aluminum Profile Working Table

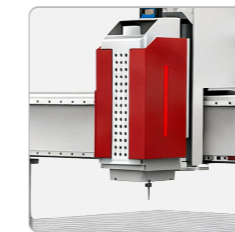

Air-Cooling Spindle



Independent Control Cabinet with DSP Handheld Controller



Gantry Side Support and Precision Linear Rails

DIMENSIONS

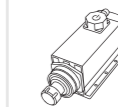
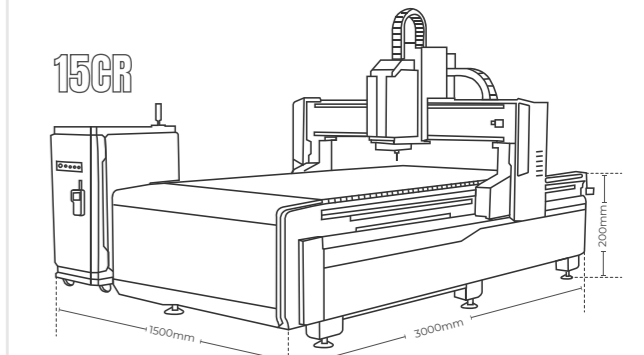
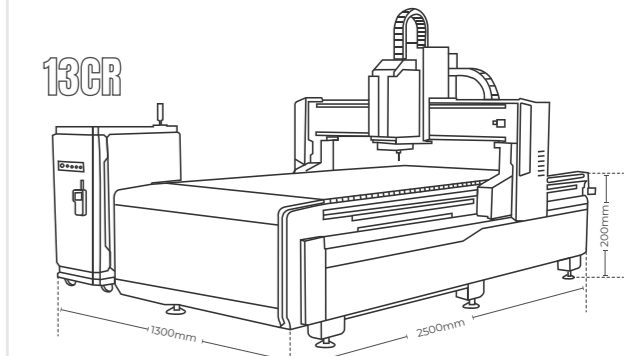

HDQ 6.0 KW Head Motor

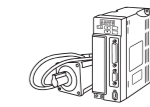

Delta 750W servo motor and driver



Delta inverter 7.5kw



DCR-50 electric automatic lubrication oil pump

PANEL SAWS

AMUZMA®

Firma 40PL



Forte 40PA



ELITE 35TS



Firma 35PS



Forte 35EU



ELITE 35PS



AMUZMA Panel Saw Series — Built for Every Scale of Production

From the compact Elite 35TS to the heavy-duty Firma 40PL, the AMUZMA panel saw lineup covers blade diameters from 315mm to 400mm, sliding beams up to 3200mm, and motor outputs between 4kW and 5.5kW. Six models, one consistent standard of precision — engineered to match any workshop size, production volume, or market requirement.

SPECIFICATIONS

TECHNICAL FEATURE	FIRMA 40PL	FORTE 40PA	ELITE 35TS	FIRMA 35PS	FORTE 35EU	ELITE 35PS
Blade specifications						
Main blade diameter	400 mm	400 mm	315 mm	315 mm	315 mm	350 mm
Main blade speed	4500 rpm	30 rpm	4500 rpm	4500 rpm	3400 rpm/50Hz	4000 rpm
Scoring blade diameter	120 mm	120 mm	120 mm	120 mm	120 mm	120 mm
Scoring blade speed	8000 rpm	8500 rpm	8000 rpm	8000 rpm	7600 rpm/50Hz	8000 rpm
Blade tilt	0–45°	0–45°	0–45°	0–45°	0–45°	0–45°
Cutting performance						
Max depth of cut @ 45°	85mm	85 mm	67 mm	67 mm	65 mm	67 mm
Max depth of cut @ 90°	125mm	125 mm	95 mm	95 mm	93 mm	90 mm
Max rip capacity	1250mm	1300 mm	900 mm	1250 mm	975 mm	1250 mm
Sliding beam (standard)						
Sliding beam size	3200×418 mm	3200×435 mm	1200×360 mm	3200×360 mm	3000×360 mm	3200×375 mm
Sliding beam cutting capacity	3200 mm	3200 mm	1250 mm	3200 mm	3000 mm	3200 mm
Blade mechanism (standard)						
Blade rising	Manual	Manual	-	Manual	Manual	Manual
Blade tilting	Manual	Motor	-	Manual	Manual	Manual
Machine body						
Table size	1020(690+720) mm	-	800×530 mm	800(530+820) mm	819(374+650) mm	800×470 mm
Dust extraction outlet	100mm	100 mm	120 mm	120 mm	100 mm	120 mm
Motor (standard)						
Main motor output	3×400V / 5.5kW S1	3×400V / 5.5kW / 7.5HP	3×400V / 4kW S1	3×400V / 5kW S1	3×380V / 4kW	3×380V / 5kW
Scoring motor output	0.75kW S1	0.1kW	0.75kW S1	0.75kW S1	-	0.75kW S1
Weight & dimensions						
Net / gross weight	760 / 870 kg	800 / 850 kg	400 / 460 kg	560 / 680 kg	452 / 527 kg	561 / 680 kg
Length	6700 mm	6700 mm	2550 mm	6700 mm	6700 mm	6700 mm
Width	5790 mm	5790 mm	920 mm	3900 mm	4450 mm	4450 mm
Height	1480 mm	1480 mm	860 mm	1510 mm	1350 mm	1350 mm

PANEL SAW
Firma 40PL

AMUZMA[®]



Heavy-Duty Performance. Professional Precision.

The Firma 40PL is a powerful 16" panel saw for medium-sized workshops, offering a 3200mm cutting capacity. Built with industrial-grade materials, it ensures smooth, accurate cuts in MDF, plywood, laminates, and hardwood. Durable and precise, it's ideal for growing businesses.

SPECIFICATIONS

Main Blade Diameter	400 mm	Blade Tilting	<input checked="" type="checkbox"/> Standard	Manual Tilting
Main Blade Speed	4500 rpm		<input type="checkbox"/> Option	Motor Tilting
Scoring Blade Diameter	120 mm	Table Size	1020(690+720) mm	
Scoring Blade Speed	8000 rpm	Dust Extraction Outlet	100mm	
Blade Tilt	0-45°	Main Motor Output	<input checked="" type="checkbox"/> 3*400V 5.5kW S1	
Max Depth of Cut @ 45°	85 mm		<input type="checkbox"/> 3*400V 7kW S1	
Max Depth of Cut @ 90°	125 mm	Scoring Motor Output	0.75kW S1	
Max Rip Capacity	1250 mm	Net/Gross Weight	760/870kgs	
Sliding Beam Size	<input checked="" type="checkbox"/> Standard 3200x418 mm	Package size	<input checked="" type="checkbox"/> Pallet 2300x1190x910/3675x505x280 mm	
	<input type="checkbox"/> Option 3800 x 418 mm		<input type="checkbox"/> Wood box 2300x1190x910/3675x505x280 mm	
Sliding Beam Cutting Capacity	<input checked="" type="checkbox"/> Standard 3200 mm	Dimensions		
	<input type="checkbox"/> Option 3800 mm	Length	6700 mm	
Blade Rising	<input checked="" type="checkbox"/> Standard Manual Raised	Width	5790 mm	
	<input type="checkbox"/> Option Motor Raised	Height	1480 mm	

Standard Equipment Optional Equipment

ACCESSORIES



Scoring Blade Adjustment Knob



Handwheel for Blade Tilt



Overhead Saw Blade Guard



Sliding Table Handle and Control Panel

DIMENSIONS

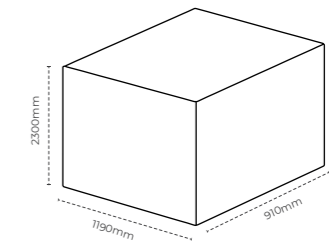
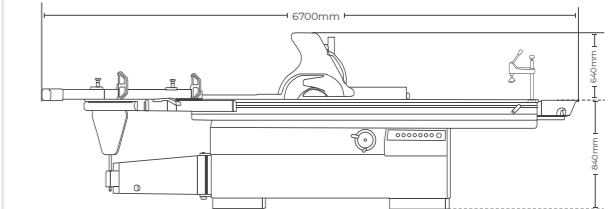
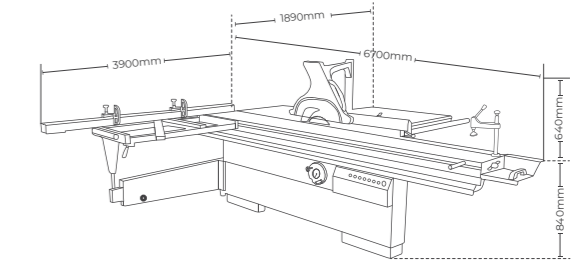

PANEL SAW
Forte 40PA

AMUZMA[®]



Forte 40PA Panel Saw – Precision Cutting Solution

A reliable panel saw designed for precise, smooth, and efficient cutting of MDF, plywood, laminated boards, and solid wood panels. Its strong motor and sliding beam system ensure stable performance for professional woodworking. Perfect for furniture factories, carpentry workshops, and industrial panel processing.

SPECIFICATIONS

Main Blade Diameter	400 mm	Blade Raising	Manual Raised
Spindle Diameter	30 mm	Blade Tilting	Motor Tilting
Main Blade Speed	30 rpm	Dust Extraction Outlet	100mm
Scoring Blade Diameter	120 mm	Main Motor Output	
Scoring Blade Speed	8500 rpm	<input checked="" type="checkbox"/> 3*400V	5.5kW / 7.5HP
Spindle of Scoring Saw	20 mm	<input type="checkbox"/> 3*400V	7.5 kW / 10 HP
Blade Tilt	0-45°	Scoring Motor Output	0.1kW
Max Depth of Cut @ 45°	85 mm	Net/Gross Weight	800/850kgs
Max Depth of Cut @ 90°	125 mm	Package size	
Max Rip Capacity	1300 mm	Wood box	2300 X 1190 X 1000 mm
Sliding Beam Size		Dimensions	
<input checked="" type="checkbox"/> Standard	3200×435 mm	Length	6700 mm
<input type="checkbox"/> Option	3800×435 mm	Width	5790 mm
Sliding Beam Cutting Capacity		Height	1480 mm
<input checked="" type="checkbox"/> Standard	3200 mm		
<input type="checkbox"/> Option	3800 mm		

Standard Equipment
 Optional Equipment

ACCESSORIES



Overhead Saw Blade Guard (Crown Guard)



Outrigger Table (Crosscut Support Table)



Digital Readout (DRO) for Rip Fence



Carriage Handle

DIMENSIONS

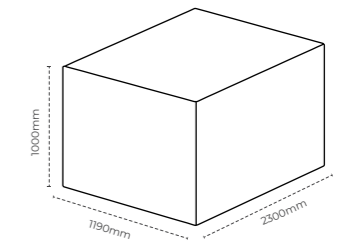
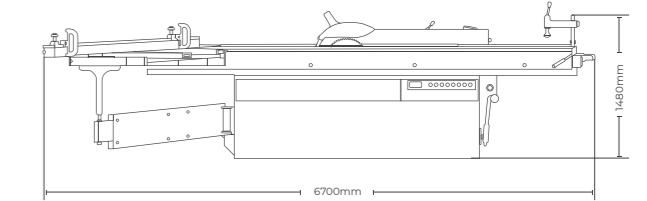
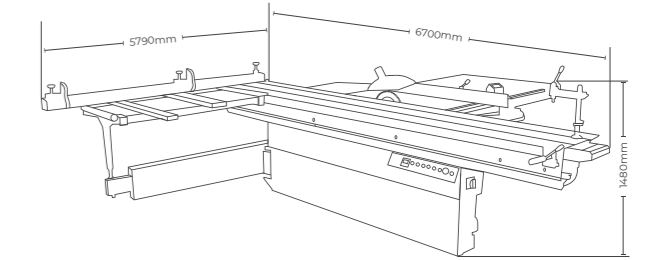

PANEL SAW
Elite 35TS

AMUZMA[®]



Compact Power, Precision Cutting

This heavy-duty panel saw is specifically engineered for small spaces, allowing workshops with limited footprints to achieve full-sized performance. Built with a cast iron table and a robust steel frame, the machine provides the stability and strength required for professional-grade durability. It is designed to deliver smooth, accurate cuts consistently, making it a perfect and versatile solution for processing both panels and solid timber.

SPECIFICATIONS

Blade Specifications		Sliding Beam Cutting Capacity	
Main Blade Diameter	315 mm	<input checked="" type="checkbox"/> Standard	1250 mm
Main Blade Speed	4500 rpm	<input type="checkbox"/> Option	1600 mm
Scoring Blade Diameter	120 mm	Table Size	800 x 530 mm
Scoring Blade Speed	8000 rpm	Dust Extraction Outlet	120 mm
Blade Tilt	0-45°	Main Motor Output:	
Max Depth of Cut @ 45°	67 mm	3*400V	4kW S1
Max Depth of Cut @ 90°	95 mm	3*400V	2.5kW S1
Max Rip Capacity		3*400V	5kW S1
<input checked="" type="checkbox"/> Standard	900 mm	1*230V	3kW S1
<input type="checkbox"/> Option	1250 mm	Scoring Motor Output	0.75kW S1
Sliding Beam Size		Net/Gross Weight	400/460 kgs
<input checked="" type="checkbox"/> Standard	1200 x 360 mm	Package Size	1300 x 1000 x 1100 mm
<input type="checkbox"/> Option	1600 x 360 mm	Dimensions	
		L x W x H	2550 x 920 x 860 mm

Standard Equipment Optional Equipment

ACCESSORIES



Crosscut Miter Fence



Blade Tilt Handwheel

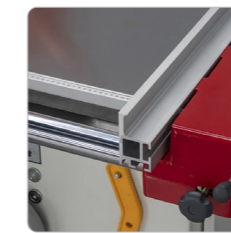

Rip Fence with Micro-Adjustment Mechanism

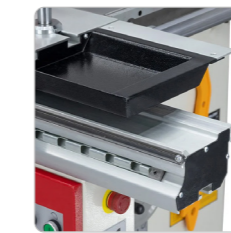

Sliding Table with End with Tool Tray

DIMENSIONS

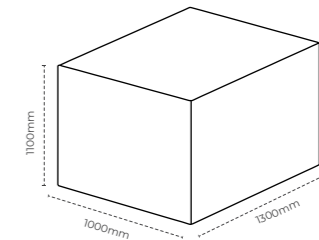
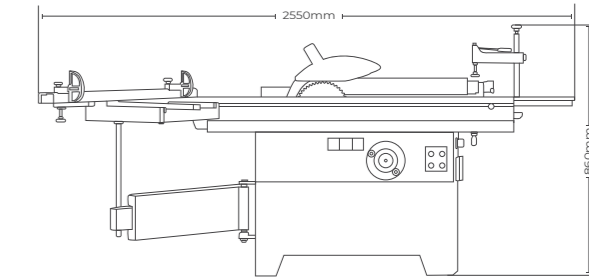
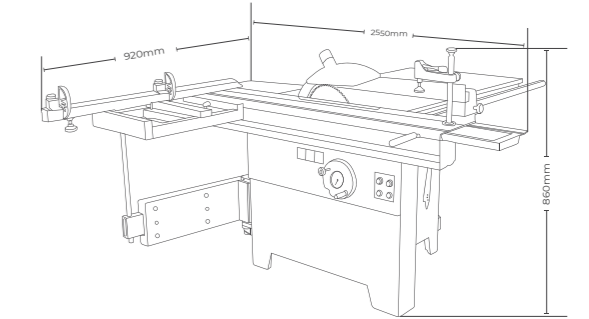

PANEL SAW
Firma 35PS

AMUZMA®



Compact Power for Precision Cutting

The Firma 35PS is a space-saving, high-performance panel saw built for small to mid-sized workshops. Despite its compact size, it offers full-scale industrial precision, effortlessly cutting panels up to 3200mm. Ideal for furniture, cabinetry, and woodworking, it features a motorized blade rise for smooth, efficient operation.

SPECIFICATIONS

Main Blade Diameter	315 mm	Blade Tilting	Standard	Manual Tilting
Main Blade Speed	4500 rpm	Option	Motor Tilting	
Scoring Blade Diameter	120 mm	Table Size	800(530+820) mm	
Scoring Blade Speed	8000 rpm	Dust Extraction Outlet	120mm	
Blade Tilt	0-45°	Main Motor Output		
Max Depth of Cut @ 45°	67 mm	3*400V	5kW S1	
Max Depth of Cut @ 90°	95 mm	3*400V	4kW S1	
Max Rip Capacity	1250 mm	Scoring Motor Output	0.75kW S1	
Sliding Beam Size		Net/Gross Weight	560/680kgs	
<input checked="" type="checkbox"/> Standard	3200x360 mm	Package size		
<input type="checkbox"/> Option	2200/2600/3800x360 mm	Pallet	2300x1080x1150/3615x480x210 mm	
Sliding Beam Cutting Capacity		Wood box	2300 X 1160 X 1160/3615x480x210 mm	
<input checked="" type="checkbox"/> Standard	3200 mm	Dimensions		
<input type="checkbox"/> Option	2200/2600/3800 mm	L	6700 mm	
Blade Rising		W	3900 mm	
<input checked="" type="checkbox"/> Standard	Manual Raised	H	1510 mm	
<input type="checkbox"/> Option	Motor Raised			

Standard Equipment Optional Equipment

ACCESSORIES



Sliding Carriage Handle and Control Panel



Main and Scoring Blade Assembly



Manual Handwheel for Blade Tilt



Sliding Table Carriage End Grip

DIMENSIONS

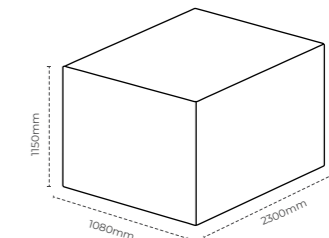
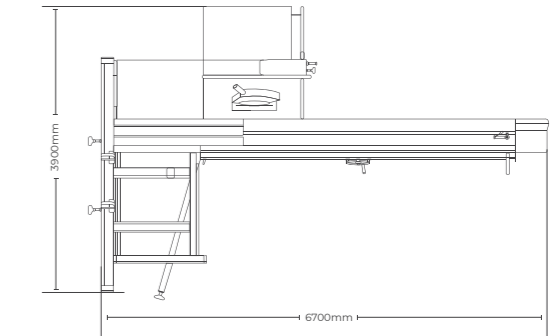
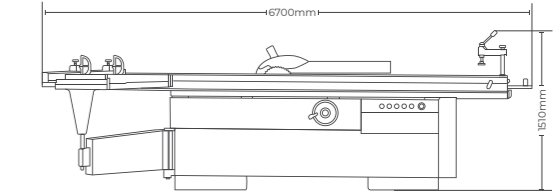

PANEL SAW
Elite 35EU



High-Precision 3000mm Panel Saw

This industrial-grade panel saw features a robust 3000 mm sliding beam and a dual-blade system (4 kW main blade / 0.75 kW scoring blade) engineered for flawless, chip-free cutting of large sheets. Built with manual blade rising and a 0-45° smooth tilt mechanism, it delivers a maximum cutting depth of 93 mm. Combining heavy-duty reliability with precise manual control, it is the perfect core workhorse for professional woodworking workshops looking to optimize their panel sizing operations.

SPECIFICATIONS

Blade Specifications		Sliding Beam Cutting Capacity		3000 mm
Main Blade Diameter	315 mm	Table Size	819(374+650) mm	
Main Blade Speed	3400rpm/50Hz	Blade Rising	Manual Rising	
Scoring Blade Diameter	120 mm	Blade Tilting	Manual Tilting	
Scoring Blade Speed	7600rpm/50Hz	Dust Extraction Outlet	100 mm	
Blade Tilt	0-45°	Main Motor Output:		
Max Depth of Cut @ 45°	65 mm	3*380V	4 kw	
Max Depth of Cut @ 90°	93 mm	Net/Gross Weight	452/527 kgs	
Max Rip Capacity	975 mm	Package Size (Wood)	2005x1140x870 mm	
Sliding Beam Size	3000x360 mm	Dimensions		
		H	1350mm	
		L	6700mm	
		W	4450 mm	

ACCESSORIES



Blade Tilt and Height Adjustment Controls

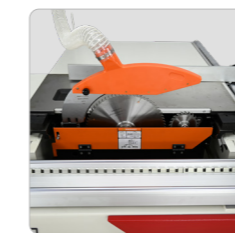

Cutting Unit Assembly, Main and scoring Blade

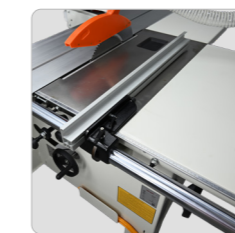

Rip Fence Assembly (Parallel Guide)



Miter Gauge Assembly

DIMENSIONS

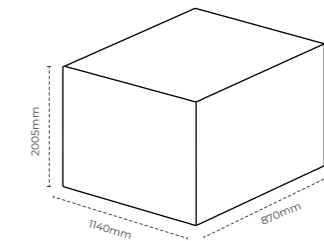
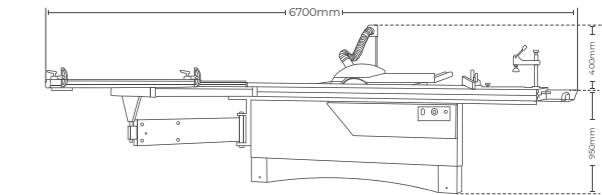
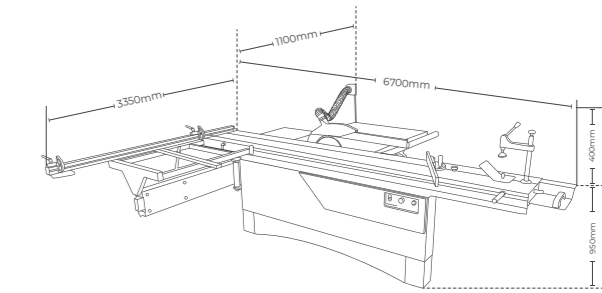

PANEL SAW
Elite 35PS



AMUZMA Elite 35PS Panel Saw

The AMUZMA Elite 35PS is a high-performance panel saw built for large-scale precision. Featuring a standard 3200 mm sliding beam, an expansive 1250 mm rip capacity, and a powerful 5 kW main motor, it easily handles demanding sheet sizing jobs. With its heavy-duty dual-blade system (350 mm main / 0.75 kW scoring) and options for motorized controls, this robust machine delivers flawless, chip-free cuts for high-output professional woodworking.

SPECIFICATIONS

Main Blade Diameter	350 mm	Blade Tilting	<input checked="" type="checkbox"/> Standard Manual Tilting
Main Blade Speed	4000 rpm	<input type="checkbox"/> Option	Motor Tilting
Scoring Blade Diameter	120 mm	Table Size	800x470mm/800x820mm
Scoring Blade Speed	8000 rpm	Dust Extraction Outlet	120mm
Blade Tilt	0-45°	Main Motor Output	3*380V 5kW
Max Depth of Cut @ 45°	67 mm	Scoring Motor Output	0.75kW SI
Max Depth of Cut @ 90°	90 mm	Angle Cutting Device	940x150x1500 mm 4/4.5 kgs
Max Rip Capacity	1250 mm	Optional accessories	
Sliding Beam Size	<input checked="" type="checkbox"/> Standard 3200x375 mm	Simple Guard	
	<input type="checkbox"/> Option 2200/2600/3800x375 mm	CE OverHead Saw Guard	
Sliding Beam Cutting Capacity	<input checked="" type="checkbox"/> Standard 3200 mm	Net/Gross Weight	561/680kgs
	<input type="checkbox"/> Option 2200/2600/3800 mm	Package size	
Blade Rising	<input checked="" type="checkbox"/> Standard Manual Raised	Wood box	2300 X 1160 X 1160/3615x480x210 mm
	<input type="checkbox"/> Option Motor Raised	Dimensions	
		L x W x H	6700 x 4450 x 1350mm

Standard Equipment Optional Equipment

ACCESSORIES



Scoring Blade Adjustment Controls



Outrigger Table and Crosscut Fence

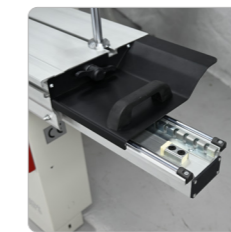

Sliding Table Push Handle



Cutting Unit, Guard Assembly

DIMENSIONS

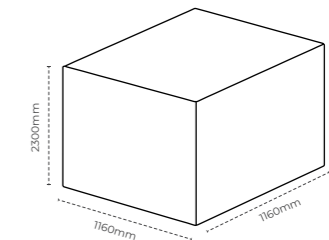
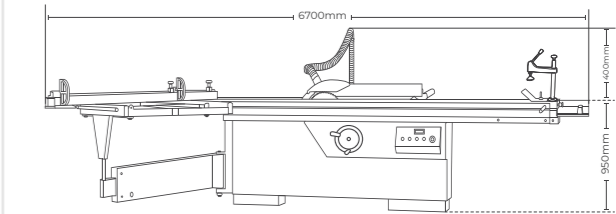
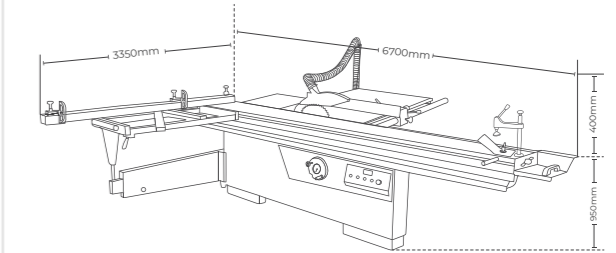

SPINDLE MOULDER
Elite 30SM

AMUZMA®



Precision Engineering. Built for Professionals.

The Spindle Moulder Elite 30SM is a high-performance machine with a durable cast iron bed, ensuring precise cuts and long-lasting reliability. Perfect for shaping, profiling, and joinery on hardwoods and composites, it delivers exceptional value for serious craftsmen."

SPECIFICATIONS

Spindle diameter	30 (32:35:40:50) mm
Spindle speeds	1400/3500/6000/8000 RPM
Max. spindle stroke	140 mm
Spindle length	130 mm
Spindle tilting	-5°+45°
Max. diameter of table opening	220 mm
Max. tool diameter above the table	200/250 mm
Height of table	890 mm
Max. height of machine	1300 mm
Table size	1000 x 350 mm
Suction dust hood diameter	100 mm
Motor	
■ 3*400V	4 kW S6
□ 1*230V	3 kW S6
Net/Gross Weight	235/280 kg
Package Size	1150 x 900 x 1085 mm
Dimensions (H x L x W)	1300 x 1000 x 1400mm

■ Standard Equipment □ Optional Equipment

ACCESSORIES



Spindle Tilt Handwheel and Angle Scale



Sliding Table End with Pull Handle



Moulder Fence Hood with Dust Extraction Port



Spindle Height Handwheel and Main Control Panel

DIMENSIONS

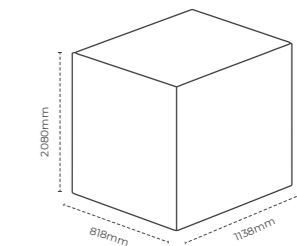
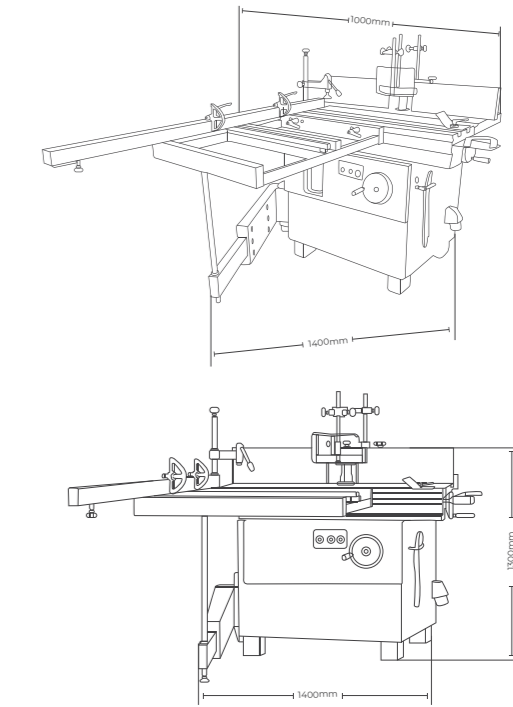

PLANER & THICKNESSERS

PLANER & THICKNESSERS
Elite 41CM



PLANER & THICKNESSERS
Elite 41CS



PLANNER
Elite 41PF



The Elite Planer and Thicknesser Series

The Elite series provides professional woodworking solutions through its range of high-performance timber preparation machinery. The lineup features dual-purpose combination models (Elite 41CM, 41CS, and 41PF) that efficiently handle both surface planing and thicknessing in a single footprint, alongside dedicated standalone thicknessers (Elite 41TH and the high-capacity, digitally controlled Firma 63TH) built for heavy-duty dimensioning. Together, these rugged machines deliver the precision and power required to transform raw lumber into perfectly smooth, uniform, and squared stock for industrial production.

THICKNESSERS
Elite 41TH



THICKNESSERS
Firma 63TH



AMUZMA

PLANER & THICKNESSER

TECHNICAL SPECIFICATIONS	ELITE 41CM	ELITE 41CS
Feed Speed	7m/min	7m/min
Cutter block Speed	5500rpm	5500rpm
Cutter block Diameter	70mm	70mm
Max Thicknesser Height	4-225mm	4-225mm
Max Thicknesser Width	410mm	410mm
Min Length of Workpiece	160mm	160mm
Max Depth of Cut	4mm	4mm
Depth Indicator		
Scale	■	■
Digital Readout	□	□
Cutterhead		
Straight Knives	3pcs/410x30x3mm	3pcs/410x30x3mm
2 Slot Spiral	44pcs/15x15x2.5mm	44pcs/15x15x2.5mm
Over Length of Planer Tables	1669mm	1669mm
Thickness Table Size	650-407mm	650-407mm
Extractor Port Dia	120mm	120mm
Cutting Motor Output		
■ 3*400V	4kW S6	4kW S6
□ 1*230V	3kW S6	3kW S6
Net/Gross Weight	294/352kgs	294/352kgs
Package Size		
H	1710mm	1710mm
L	740mm	740mm
W	1117mm	1117mm
Dimensions		
H	1002mm	1002mm
L	1659mm	1659mm
W	1350mm	1350mm

■ Standard Equipment □ Optional Equipment

PLANNER

Cutter block Speed	5500rpm
Cutter block Diameter	70mm
Max Depth of Cut	4mm
Cutterhead	
■ Straight Knives cutterhead	3pcs/410x30x3mm
□ 2 Slot Spiral Cutterhead	44pcs/15x15x2.5mm
Over Length of Planer Tables	2000mm
Extractor Port Dia	120mm
Cutting Motor Output	
■ 1*230V	3kW S6
□ 3*400V	4kW S6
Net/Gross Weight	290/351kgs
Package Size	2118*818*1138mm
Dimensions	
H x L x W	2080mm x 780mm x 1127mm

THICKNESSERS

TECHNICAL SPECIFICATIONS	ELITE 41TH	FIRMA 63TH
Feed Speed	6.5 m/min	4-16m/min (variable speed)
Cutter block Speed	4200 rpm	5500 rpm
Cutter block Diameter	95 mm	115 mm
Max Thicknesser Height	4-220 mm	5-300 mm
Max Thicknesser Width	410 mm	630 mm
Min Length of Workpiece	5mm	280 mm
Max Depth of Cut	4mm	8 mm
Depth Indicator	Scale	-
Cutterhead		
■ Straight Knives Cutterhead	3pcs/410x30x3mm	4pcs/630x30x3mm
□ 3 Slot Spiral Cutterhead	54pcs/15x15x2.5mm	104pcs/15x15x2.5mm
□ 4 Slot Spiral Cutterhead	72pcs/15x15x2.5mm	156pcs/15x15x2.5mm
Thickness Table Size	750x408 mm	1050x630 mm
Extractor Port Dia.	120 mm	150 mm
Cutting Motor Output		
■	3*400V - 4kW S6	3*400V - 5.5kW S1
□	1*230V - 3kW S6	3*400V - 7.5kW S1
Lifting Motor Output	-	0.25kW
Feeding Motor Output	-	0.55kW
Net/Gross Weight	306/367kgs	650/716 kgs
Package Size	740x710x1117 mm	1220x1150x1315mm
Dimensions (H x L x W)	954mm x 700mm x 900mm	1150mm x 1200mm x 1220mm

PLANER & THICKNESSER
Elite 41CM



Versatile, Powerful, Precise

The Planer and Thicknesser 16 Elite 41CM handles large timber with ease (410mm width, 255mm height). Switch between surfacing and thicknessing effortlessly with a single-handed table lift. The extra-large aluminium fence ensures stability, and quick, accurate adjustments are made with cantered controls and cam-locking mechanisms."

SPECIFICATIONS

Feed Speed	7m/min	Cutting Motor Output	
Cutter block Speed	5500rpm	<input checked="" type="checkbox"/> 3*400V	4kW S6
Cutter block Diameter	70mm	<input type="checkbox"/> 1*230V	3kW S6
Max Thicknesser Height	4-225mm	Net/Gross Weight	294/352kgs
Max Thicknesser Width	410mm	Package Size	1710x740x1117mm
Min Length of Workpiece	160mm	Dimensions	
Max Depth of Cut	4mm	H	1002mm
Depth Indicator		L	1659mm
<input checked="" type="checkbox"/> Scale		W	1350mm
<input type="checkbox"/> Digital Readout			
Cutterhead			
<input checked="" type="checkbox"/> Straight Knives	3pcs/410x30x3mm		
<input type="checkbox"/> 2 Slot Spiral	44pcs/15x15x2.5mm		
Over Length of Planer Tables	1669mm		
Thickness Table Size	650-407mm		
Extractor Port Dia	120mm		

Standard Equipment Optional Equipment

ACCESSORIES



Manual Handwheel with Readout

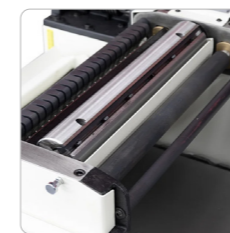

Helical Cutterhead Assembly

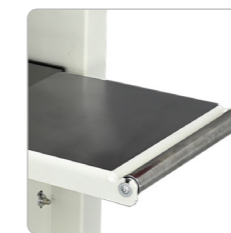

Thicknessing Table Extension



Adjustment Lever

DIMENSIONS

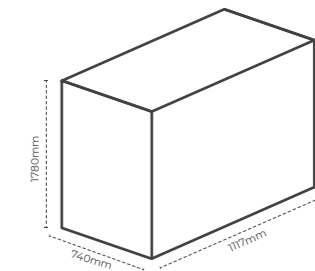
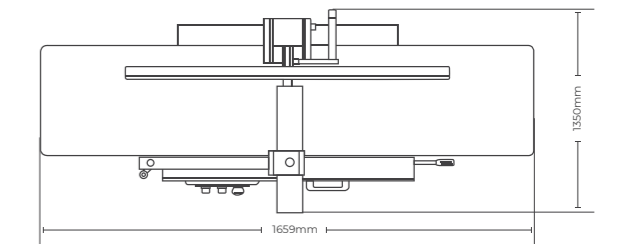
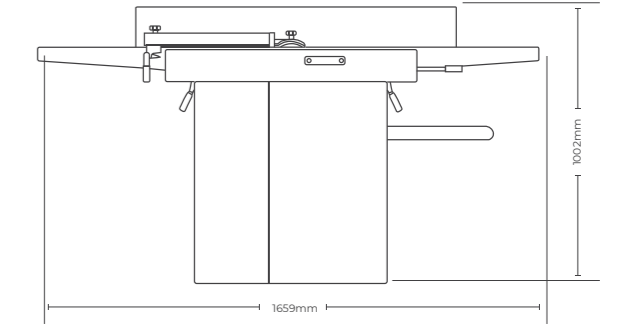

PLANER & THICKNESSER Elite 41CS



Versatile, Powerful, Precise

The Planer and Thicknesser 16 Elite 41CS handles large timber with ease (410mm width, 255mm height). Switch between surfacing and thicknessing effortlessly with a single-handed table lift. The extra-large aluminium fence ensures stability, and quick, accurate adjustments are made with centered controls and cam-locking mechanisms."

SPECIFICATIONS

Feed Speed	7m/min	Cutting Motor Output	
Cutter block Speed	5500rpm	<input checked="" type="checkbox"/> 3*400V	4kW S6
Cutter block Diameter	70mm	<input type="checkbox"/> 1*230V	3kW S6
Max Thicknesser Height	4-225mm	Net/Gross Weight	294/352kgs
Max Thicknesser Width	410mm	Package Size	1710x740x1117mm
Min Length of Workpiece	160mm	Dimensions	
Max Depth of Cut	4mm	H	1002mm
Depth Indicator		L	1659mm
<input checked="" type="checkbox"/> Scale		W	1350mm
<input type="checkbox"/> Digital Readout			
Cutterhead			
<input checked="" type="checkbox"/> Straight Knives	3pcs/410x30x3mm		
<input type="checkbox"/> 2 Slot Spiral	44pcs/15x15x2.5mm		
Over Length of Planer Tables	1669mm		
Thickness Table Size	650-407mm		
Extractor Port Dia	120mm		

Standard Equipment Optional Equipment

ACCESSORIES



Manual Handwheel with Readout



Helical Cutterhead Assembly

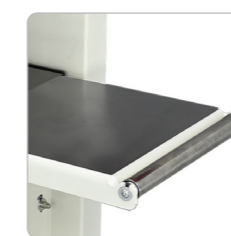

Thicknessing Table Extension



Adjustment Lever

DIMENSIONS

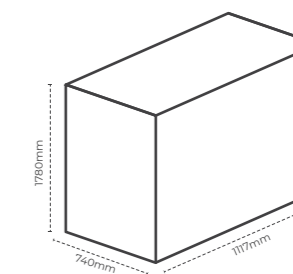
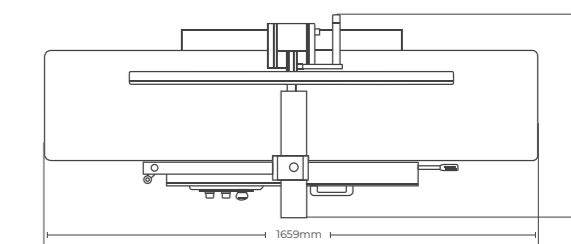
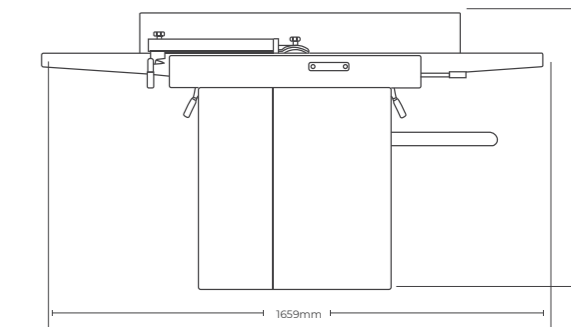



Long Bed. Solid Build. Precise Results

The Planer 16" Elite 41PF offers superior accuracy and support for long workpieces. With heavy-duty cast iron tables and a parallelogram adjustment system, it ensures vibration-free performance. The robust fence and front-mounted controls enable fast, precise adjustments for efficient operation.

SPECIFICATIONS

Cutter block Speed	5500rpm
Cutter block Diameter	70mm
Max Depth of Cut	4mm
Cutterhead	
<input checked="" type="checkbox"/> Straight Knives cutterhead	3pcs/410x30x3mm
<input type="checkbox"/> 2 Slot Spiral Cutterhead	44pcs/15x15x2.5mm
Over Length of Planer Tables	2000mm
Extractor Port Dia	120mm
Cutting Motor Output	
<input type="checkbox"/> 3*400V	4kW S6
<input checked="" type="checkbox"/> 1*230V	3kW S6
Net/Gross Weight	290/351kgs
Package Size	2118×818×1138mm
Dimensions	
H x L x W	2080mm x 780mm x 1127mm

Standard Equipment Optional Equipment

ACCESSORIES



Main Control Panel with Emergency Stop



Bridge-Type Cutterhead Safety Guard



Precision Ground Table



Adjustment Lever

DIMENSIONS

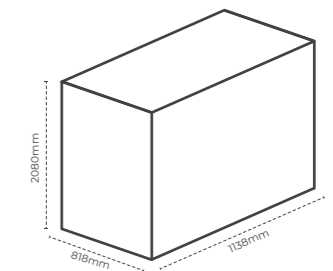
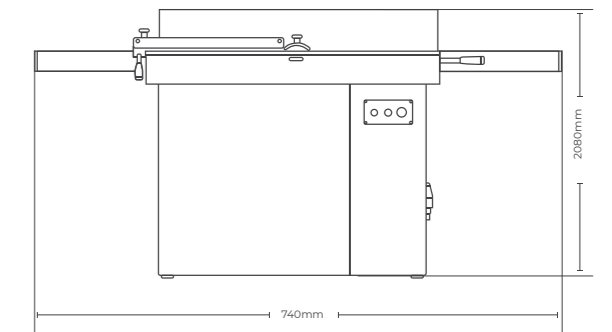
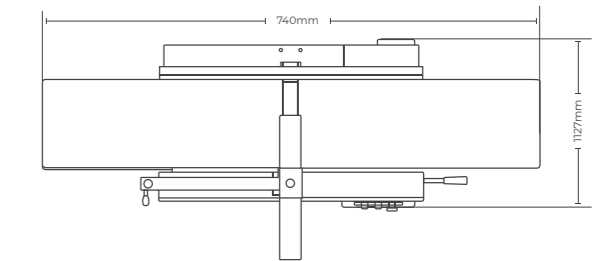

THICKNESSER Elite 41TH



AMUZMA[®]

Compact Power for Professional Results

The Elite 41TH is a heavy-duty, space-efficient thicknesser with a 410mm planing width, ideal for jointing and thickening wide boards. It delivers consistent performance with a 4mm depth of cut, even on tough hardwoods. Perfect for home workshops, small industries, or woodworking clubs seeking professional results in limited space.

SPECIFICATIONS

Feed Speed	6.5 m/min	Cutting Motor Output	
Cutter block Speed	4200 rpm	<input checked="" type="checkbox"/> 3*400V	4kW S6
Cutter block Diameter	95 mm	<input type="checkbox"/> 1*230V	3kW S6
Max Thicknesser Height	4-220 mm	Net/Gross Weight	306/367kgs
Max Thicknesser Width	410 mm	Package Size	740x710x1117 mm
Min Length of Workpiece	156mm	Dimensions	
Max Depth of Cut	5mm	H x L x W	954mm x 700mm x 900mm
Depth Indicator			
<input checked="" type="checkbox"/> Scale			
<input type="checkbox"/> Digital			
Cutterhead			
<input checked="" type="checkbox"/> Straight Knives Cutterhead 3pcs/410x30x3mm			
<input type="checkbox"/> 3 Slot Spiral Cutterhead 54pcs/15x15x2.5mm			
<input type="checkbox"/> 4 Slot Spiral Cutterhead 72pcs/15x15x2.5mm			
Thickness Table Size	750x408 mm		
Extractor Port Dia.	120 mm		

Standard Equipment Optional Equipment

ACCESSORIES

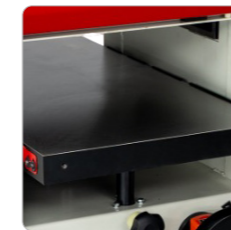

Heavy-Duty Cast-Iron Thickening Table



Table Height Handwheel



Planer Cutterhead, Power Feed Roller Assembly



Main Control Panel with Emergency Stop

DIMENSIONS

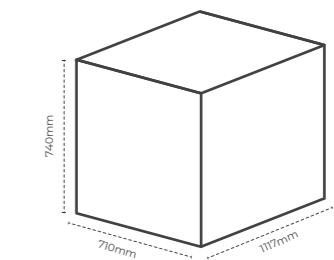
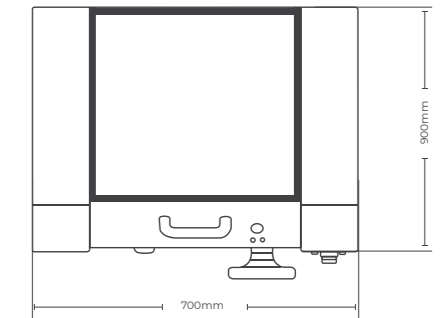
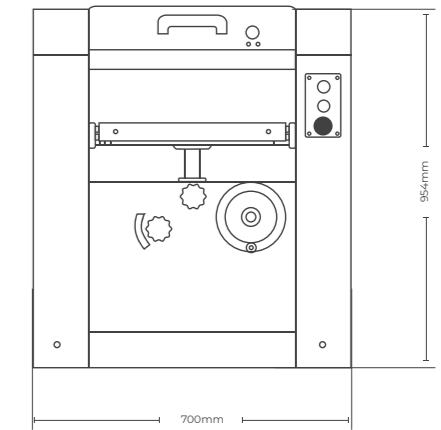

THICKNESSER Firma 63TH



AMUZMA[®]

Industrial Strength, Precision Results

Built for high-volume, professional woodworking, the Firma 63TH offers powerful performance with precision control. Features include variable feed speed, electronic table lift, and digital thickness setting. Its durable build, spring-loaded pressure bar, and four-column support ensure smooth, stable operation even under heavy loads. Reliable. Accurate. Built to last.

SPECIFICATIONS

Feed Speed	4-16m/min (variable speed)	Lifting Motor Output	0.25kW
Cutter block Speed	5500 rpm	Feeding Motor Output	0.55kW
Cutter block Diameter	115 mm	Net/Gross Weight	650/716kgs
Max Thicknesser Height	5-300 mm	Package Size	1220×1150×1315mm
Max Thicknesser Width	630 mm	Dimension	
Min Length of Workpiece	280 mm	H	1150mm
Max Depth of Cut	8 mm	L	1200mm
Cutterhead		W	1220mm
	<input checked="" type="checkbox"/> Straight Knives Cutterhead 4pcs/630x30x3mm <input type="checkbox"/> 4 Slot Spiral Cutterhead 104pcs/15x15x2.5mm <input type="checkbox"/> 6 Slot Spiral Cutterhead 156pcs/15x15x2.5mm		
Thickness Table Size	1050×630 mm		
Extractor Port Dia.	150 mm		
Cutting Motor Output			
	<input checked="" type="checkbox"/> 3*400V 5.5kW SI <input type="checkbox"/> 3*400V 7.5kW SI		

Standard Equipment Optional Equipment

ACCESSORIES



Electro-Mechanical Control Panel



Hinged Internal Chip Deflector



Heavy-Duty Thickening Bed



Outfeed Table Safety Shroud

DIMENSIONS

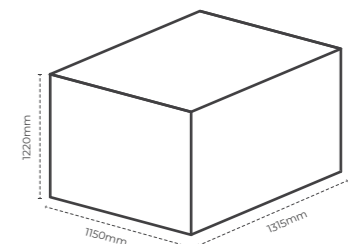
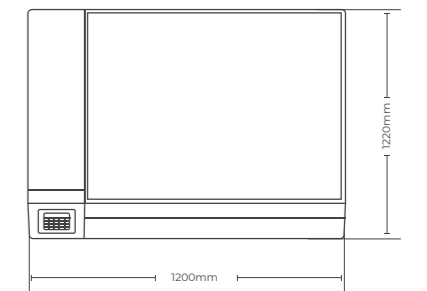
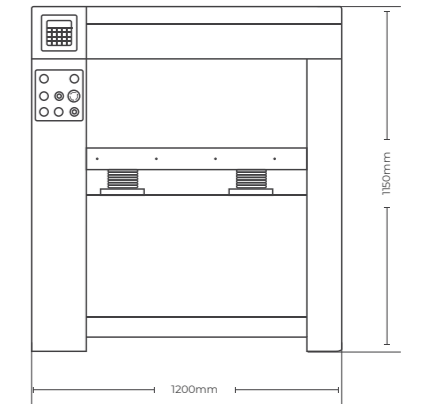



Clean Air. Quiet Power. Reliable Extraction

The ABS5000 is a powerful, high-capacity dust collector built for professional workshops and industrial use. It features strong suction, efficient filtration, and large collection bags to improve air quality and protect equipment. Its durable steel frame and low-noise operation make it a reliable, quiet addition to any workspace.

SPECIFICATIONS

Power / Voltage	230V / 50Hz
Three Phase Voltage	400V, 3 Phase, 50Hz
Motor Power	3.8 kW
Air Flow Capacity	3900 m ³ /hr
Dust Bag Capacity	380 Liter
Main Inlet Size	1 × 150 mm
Additional Inlet Size	3 × 100 mm
Packing Size	1170 × 590 × 570 mm
20 ft Container Quantity	80 pcs
40 ft Container Quantity	160 pcs
40 ft High Cube Quantity	-
Net / Gross Weight	60 / 65 kg

ACCESSORIES



Induction Motor with Magnetic Safety Switch



Multi-Port Intake Manifold



Upper High-Efficiency Filter Bags



Reinforced Base with Swivel Casters

DIMENSIONS

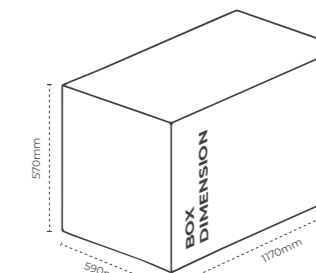
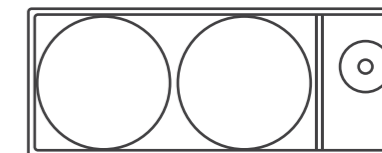
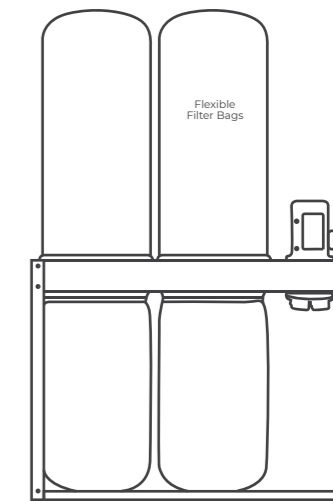



Efficient Extraction. Compact Design. Clean Results

The DC2200 is a compact and reliable dust collector, perfect for light to moderate use in smaller workshops. It offers consistent suction, a space-saving design, and an easy bag-change system—ideal for hobbyists, small businesses, and schools.

SPECIFICATIONS

Power / Voltage	230V / 50Hz
Three Phase Voltage	400V, 3 Phase, 50Hz
Motor Power	3800 W
Air Flow Capacity	5000 m ³ /hr
Dust Bag Capacity	2 x 200 Liter
Main Inlet Size	200 mm
Additional Inlet Size	4 x 100 mm
Packing Size	1590 x 610 x 525 mm
20 ft Container Quantity	50 pcs
40 ft Container Quantity	105 pcs
40 ft High Cube Quantity	131 pcs
Net / Gross Weight	60 / 65 kg

ACCESSORIES



3-Way Intake Manifold



Y-Shaped Distribution Manifold



High-Efficiency Filter Bag



Induction Motor with Magnetic Safety Switch

DIMENSIONS

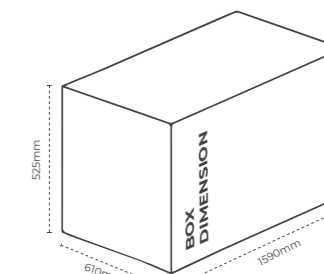
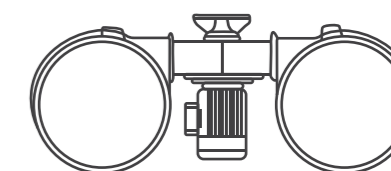
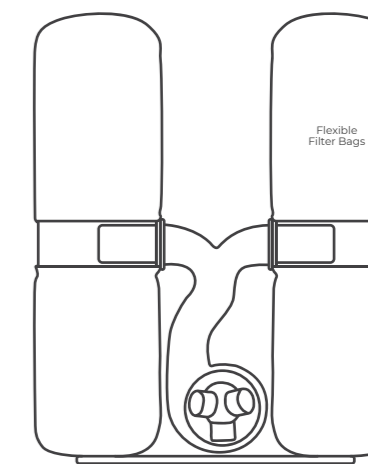



Compact Power. Reliable Dust Extraction. Workshop Ready.

The RDC3800 is a compact, high-performance dust collector ideal for small to mid-sized workshops. It combines strong suction, portability, and efficient filtration to keep your workspace clean and equipment protected. With durable steel construction and an easy-to-empty collection system, it's built for reliable daily use.

SPECIFICATIONS

Power / Voltage	230V / 50Hz
Three Phase Voltage	400V, 3 Phase, 50Hz
Motor Power	3.8 kW
Air Flow Capacity	3900 m³/hr
Dust Bag Capacity	380 Liter
Main Inlet Size	1 x 150 mm
Additional Inlet Size	3 x 100 mm
Packing Size	1170 x 590 x 570 mm
20 ft Container Quantity	80 pcs
40 ft Container Quantity	160 pcs
40 ft High Cube Quantity	-
Net / Gross Weight	60 / 65 kg
Dimensions	1170 x 590 x 570 mm

ACCESSORIES

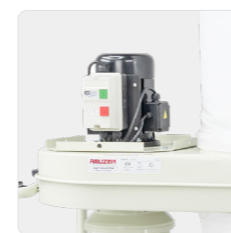

Induction Motor with Magnetic Safety Switch



Reinforced Base with Swivel Casters



High-Efficiency Filter Bag



Multi-Port Intake Manifold

DIMENSIONS

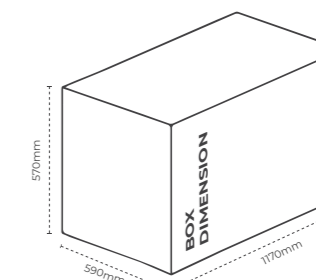
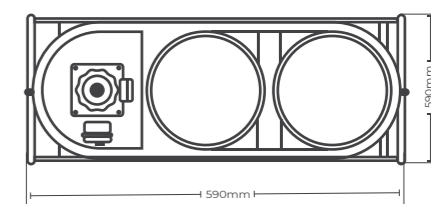
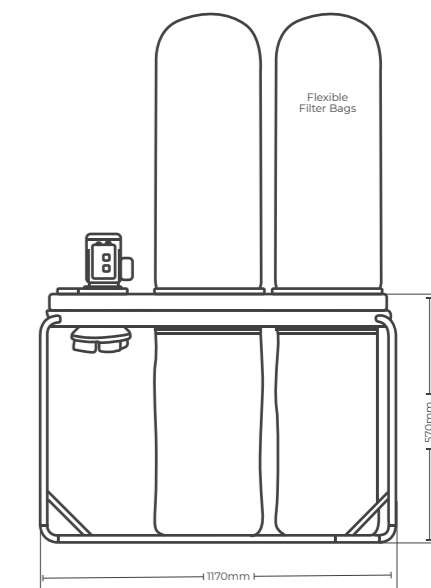

Contact Us

 +971 45478088

 +971 50 857 6840

 info@amuzmamachinery.com

 www.amuzmamachinery.com

 Ras Al Khor, Industrial Area 2,
United Arab Emirates



Website



Contact Us